



Horizontal lifting support with 10 different lifting positions, 350 kg Technical specifications

Functions

Lifting capacity, max. : 350 kg
Suspension points : 8

Weight and Materials

Total weight : 9,7 kg
Lifting hanger : Powder coated steel, RAL 9016

Measurements

A : 977 mm
B : 108 mm
C : 1425 mm
D : 510 mm
E : 500 mm
F : 547 mm
G : 558 mm
H : 716 mm
I : 212 mm

Accessories/ Miscellaneous

Lifting sling : See brochure

Labelling

The product is manufactured in compliance with the Council Directive 93/42/EEC of June 14th 1993, including amendments, as medical device class 1.

Item Number/Model

28466 : Horizontal lifting support with 10 different lifting positions

Classification

according to ISO 9999 : 12 36 03

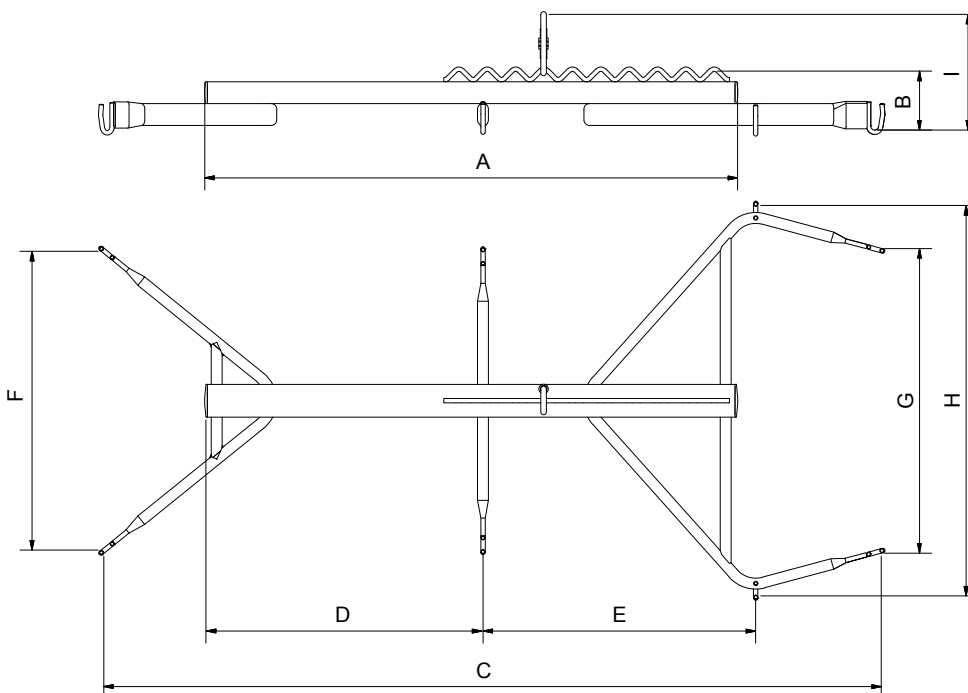

Time to care