



GH1 F Lifting module
Technical specifications

Weight and materials

SWL : 175 kg, 205 kg, 255 kg
Lifting module : 11,0 kg
Lifting module
incl. Trolley : 12,2 kg

Covers, top and bottom : Impact-resistant UL 94 V-0 flame
retardant recyclable plastic

Dimensions

A : 530 mm
B : 350 mm
C : 230 mm
D : 330 mm
E, min : 83 mm
F, min : 580 mm
G : 2500 mm
Depth of hoist : 194 mm

Functions

Operation : Hand control
Sound level : 52 dB (A)

Safety

Emergency stop : Yes
Emergency lowering
device : Yes, electrical
Control of lifting strap : Yes
Cut-off angle : 45° along the rail
10° across the rail

Electronics

On/off : Automatic when used. Soft start/stop.
Overload protection.
Battery : 1 x 24 V NiMH, 2,8 Ah
Max charge time : 3 hours
Battery protection : At battery voltage below 22 V the indi-
cator light turns yellow. The hoist stops
if the voltage falls below 20 V
Power supply : 36 V DC, 0.83 A
Supply voltage,
transformer : 100-240V AC, 47-63 Hz

Protection classification (IP) according to IEC 60529

Lifting module : IP 20
Hand control : IP 42

Labelling

The product is manufactured in compliance with the Council
Directive 93/42/EEC of June 14th 1993, including amendments,
as medical device class 1.

Classification

Pursuant to ISO 9999

Patents

: PA 2008 00888
PA 2008 00894
PA 2008 00895

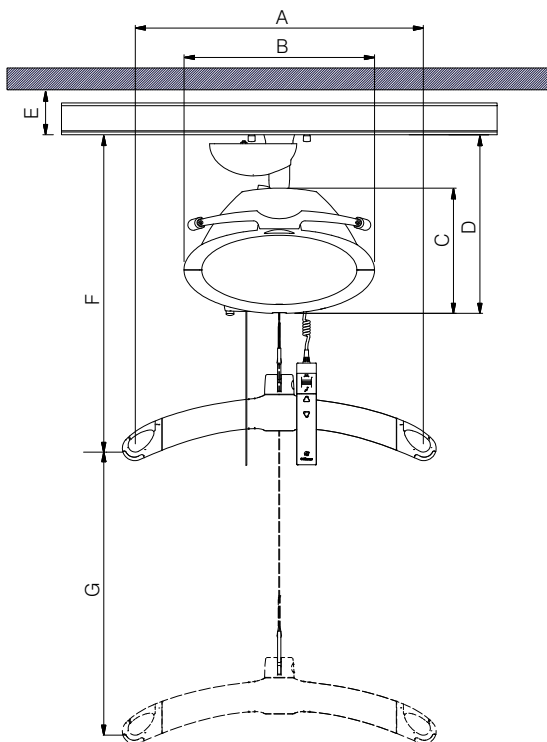

| Time to care |



GH1 F Lifting module Technical specifications

GH1 F Lifting modules, configurations									
Guldmann hoist type	Product line	Load in kg	Number of lifting straps	Number of lifting motors	Additional functions	Scale module	CLM module	Service module	User interface
GH1	(x)	xxx	x	x	x	x	x	x	x
GH1	F	175	1	1	4				0
		205	1	1	4				
		255	1	1	4				

Example: GH1 F 205 114 0000

GH1	F	205	1	1	4	0	0	0	0
-----	---	-----	---	---	---	---	---	---	---

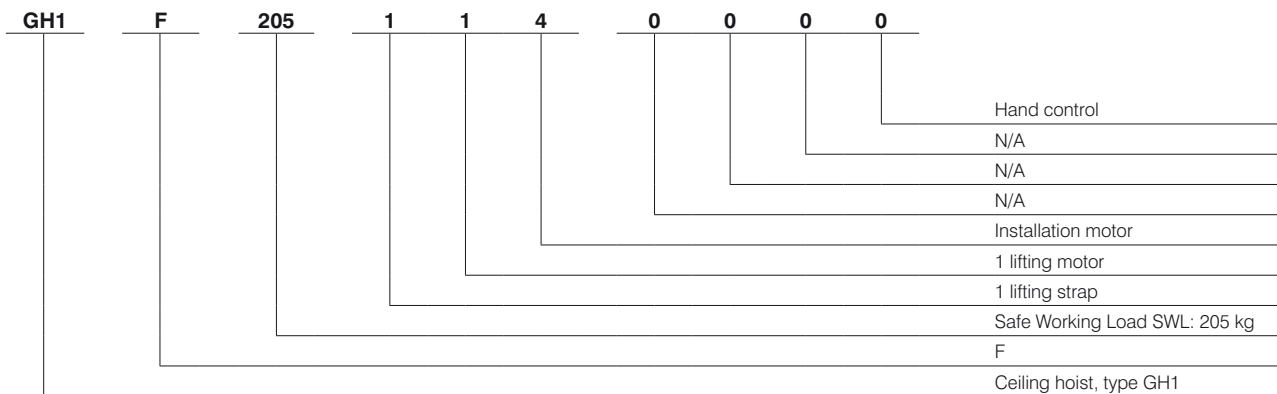

Lifting speed

85 kg load : 40 mm/sec.
 150 kg load : 40 mm/sec.
 Max capacity load, SWL : 40 mm/sec.
 Max. 5 kg kg load : 80 mm/sec.

Number of lift and Intermittent

Max. number of lifts
 in series : 55 with 85 kg/1000 mm
 Charging time : 3 hours
 Intermittent : 20/80, 4 hours

Max. number of lifts
 in series : 44 with 175 kg/1000 mm
 36 with 205 kg/1000 mm
 28 with 255 kg/1000 mm

Charging time : 3 hours
 Intermittent : 10/90, 4 hours



V. Guldmann A/S
Graham Bells Vej 21-23A
DK-8200 Aarhus N
Tel. +45 8741 3100
Fax +45 8741 3131
info@guldmann.com
www.guldmann.com

Trolley and transport trolley for GH1 F Technical specifications

Trolley for GH1 F

Functions

Max. load : 255 kg

Weight

Travelling trolley : 1.2 kg

Measurements

A : 98 mm
B : 166 mm
C*, max. : 2800 mm
D, min. : 650 mm
D, max. : 750 mm
Depth of travelling trolley : 84 mm

Transport trolley for GH1 F

Functions

Capacity, bag : 2-3 slings
2-3 lifting hangers

Capacity, max. : 25 kg

Weight

Trolley including bag : 10.4 kg

Measurements

A : 1005 mm
B : 735 mm
Depth of transport trolley : 485 mm

*Cord length C adapted to height of rail during installation

