



GB/US . . . . Horizontal lifter, foldable, 250 kg (550 lbs)

**taylordolman**

tel: 0845 838 0600

email: [info@taylordolman.com](mailto:info@taylordolman.com)

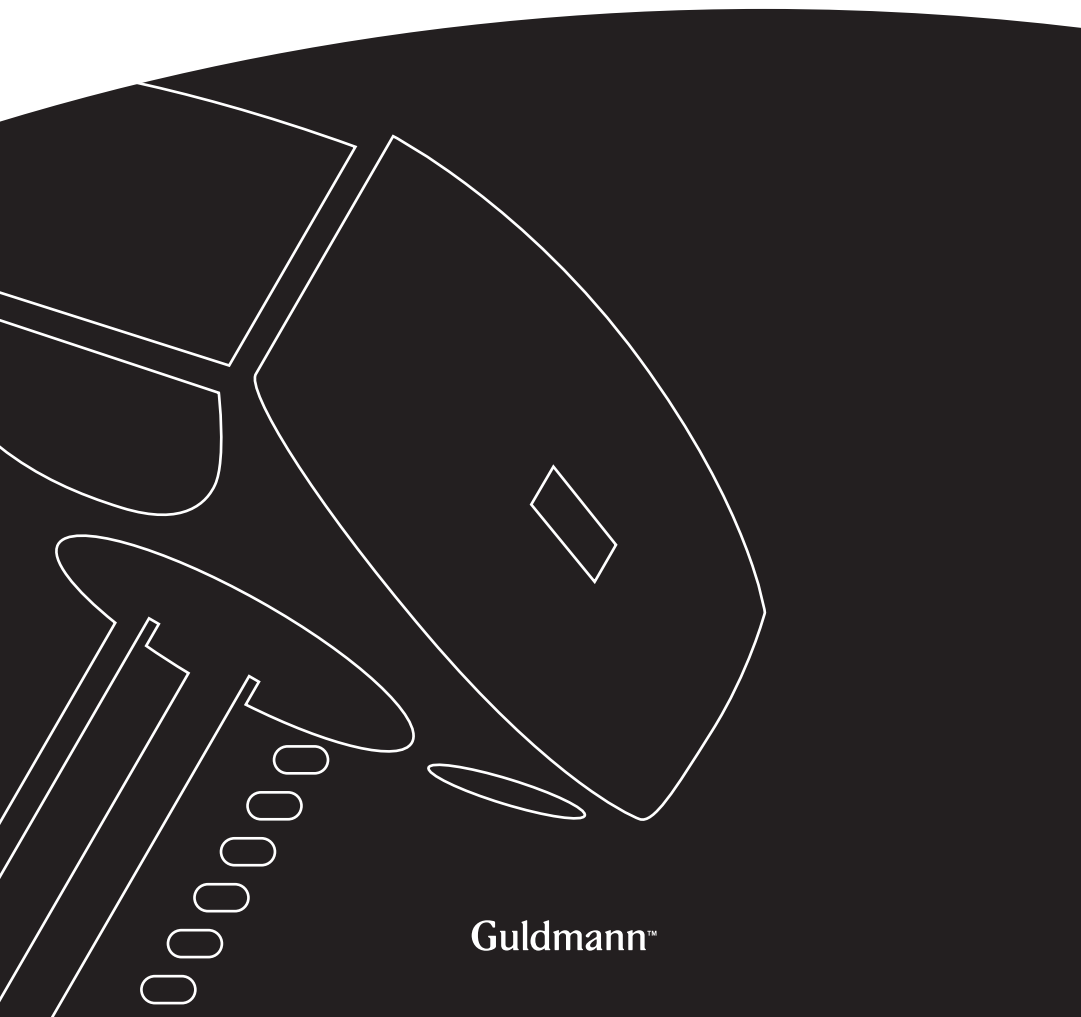

**Guldmann™**

<b>Horizontal lifter, foldable, 250 kg (550 lbs)</b>	
Item nos: 28445	
.....	<b>Horizontal lifter, foldable, 250 kg (550 lbs) ..... 2</b>
<b>1.00</b> .....	<b>Purpose and use ..... 3</b>
1.01 .....	Manufacturer ..... 3
1.02 .....	Purpose ..... 3
1.03 .....	Important/warnings ..... 3
1.04 .....	Unpacking and preparation ..... 4
1.05 .....	Before you can use the product. .... 5
1.06 .....	Sling ..... 7
<b>2.00</b> .....	<b>Description of features ..... 8</b>
2.01 .....	Labels ..... 8
2.02 .....	Accessories ..... 10
<b>3.00</b> .....	<b>Transport ..... 11</b>
<b>4.00</b> .....	<b>Maintenance and storage ..... 11</b>
4.01 .....	Cleaning and maintenance ..... 11
4.02 .....	Storage ..... 11
4.03 .....	Owner's daily maintenance obligations ..... 13
4.04 .....	Disposal of the horizontal lift ..... 13
<b>5.00</b> .....	<b>Service and service life ..... 13</b>
5.01 .....	Service life ..... 13
<b>6.00</b> .....	<b>Technical specifications ..... 14</b>
<b>7.00</b> .....	<b>CE declaration of conformity ..... 15</b>
<b>A.</b> .....	<b>Users guide ..... 16</b>
<b>B.</b> .....	<b>WARRANTIES ..... 16</b>

<b>1.00</b>	<b>Purpose and use</b>
<b>1.01</b>	<b>Manufacturer</b>
	V. Guldmann A/S Graham Bells Vej 21-23A DK-8200 Aarhus N Tel. + 45 8741 3100 Fax + 45 8741 3131
<b>1.02</b>	<b>Purpose</b>
	<b>The horizontal lifter is a lifting device which is used together with a hoist and rail system to move people in a horizontal position. It can be stored completely or partially folded in order to minimise space requirements, or it can hang ready to use in the hoist.</b>
	<b>The horizontal lifter may be used only for horizontal relocation* of people lying on a level, horizontal surface. A level surface can be, for example, a bed, a stretcher or the floor.</b>
	<b>Prerequisites</b> The use of the horizontal lifter is subject to the following prerequisites:
	<ul style="list-style-type: none"> <li>• The device/working tool is used by trained personnel.</li> <li>• The assistant pays attention to the well-being of the user/patient when using the product.</li> <li>• The product may be used only with a hoist and rail systems which have been tested and approved according to Guldmann's instructions.</li> </ul>
	<i>* A horizontal relocation is defined as a relocation of a person lying on a horizontal surface where the horizontal position is kept during a vertical, horizontal or combined movement. The surface can be completely level or at an angle suited to the respective situation.</i>
<b>1.03</b>	<b>Important/warnings</b>
	Always exercise caution when using the horizontal lifter. This means that assistants should always make sure that they, the user/patient and any other persons are safe so as to avoid injuries or accidents.
	<ul style="list-style-type: none"> <li>• Please read the user manual before you start using the horizontal lifter.</li> <li>• Do not exceed the horizontal lifter's recommended load of 250 kg (550 lbs).</li> <li>• Products marked with the lowest carrying capacity determine the maximum load.</li> <li>• Use the horizontal lifter only to move people "in a horizontal position".</li> <li>• If a defect appears during use of the horizontal lifter, stop using it and contact the Guldmann Service Team for repairs.</li> <li>• The user/patient in the horizontal lifter must always be under supervision</li> </ul>

- and may not turn or move in the lengthwise direction when lying in the lifter.
- To avoid unintentional movements of the horizontal lifter, you must position the hoist centrally over the horizontal lifter before you start lifting.
  - When the horizontal lifter is lowered with a user/patient, the lifter may never rest on the user/patient. This could happen in two situations:

a. *When the user/patient is unloaded onto a bed which is narrower than the lifter 770 mm (30¾")*

The horizontal lifter could continue lowering by the side of the bed and thereby rest on the user/patient. See figure 1.

b. *When the user/patient is unloaded onto a bed which is wider than the lifter 770 mm (30¾")*

The horizontal lifter could rest on the bed which the user/patient lies on and thereby open up so that the central part rests on the user/patient. The horizontal lifter can, however, remain closed during unloading if the lifting sling or the sling straps are firmly tightened. If the straps are loosened in this situation, the lifter will open suddenly and rest on the user/patient. See figure 2.

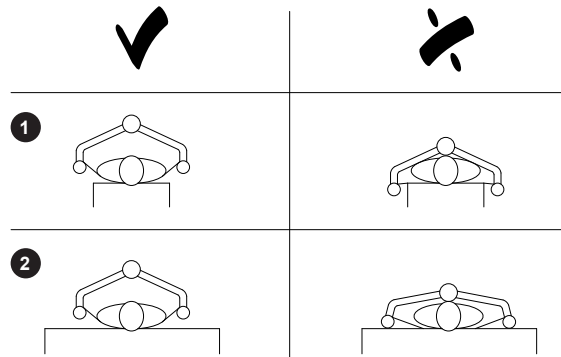

## 1.04 Unpacking and preparation

### Visual check of the horizontal lifter

If the horizontal lifter is thought to be damaged upon receipt, it must not be used before it is checked and approved by a qualified person or the Guldmann Service Team.

### The contents of the box

- Horizontal lifter
- Sling, incl. bracing struts
- Wall mount bracket (storage)
- Manual

## 1.05 Before you can use the product

The horizontal lifter is a foldable working tool which can be suspended in a hoist and unfolded before use. It can be stored in three ways:

- On a wall bracket, hanging down the wall.
- In a strap retainer suspended in the hoist, so as to save space.
- In a specially furnished transport trolley where it can be transported to alternative places of use or to storage/cleaning.

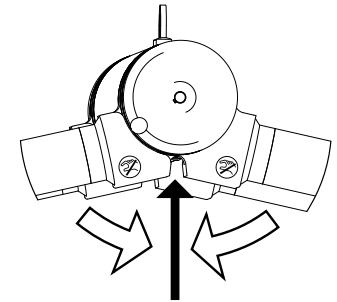

**In connection with the unfolding of the horizontal lifter, there is a risk of getting your fingers caught – see illustration.**



### Set up from a wall bracket (storage)

Attach the snap hook of the hoist to the lifting eye of the horizontal lifter manually and unfold the lifter by raising the hoist.

**Be careful not to get your fingers caught during unfolding.**

When the horizontal lifter unfolds fully, it is ready for use.

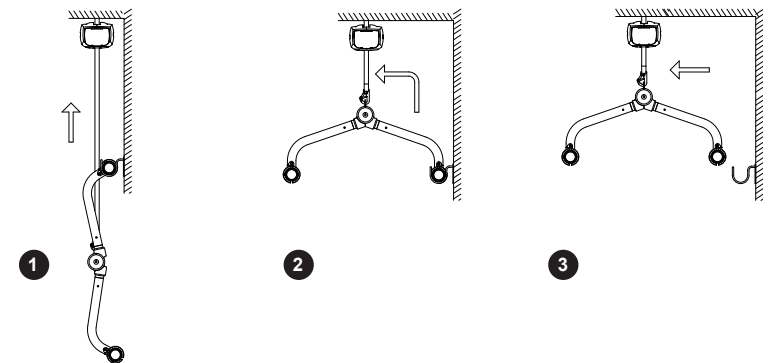

### Set up from a strap retainer (accessory)

Release the upper telescopic arm from the locking clip with the telescopic arm at the height of your shoulders and swing it carefully down in a position where it is ready for use.

However, you must make sure you have a firm grip of the telescopic arm before release so that it does not swing down uncontrolled with a risk for injuries to people or to the surroundings. It is recommended that this task be done by two people – one to hold the hanger and another one to release/lock the lifter from the strap retainer.

**Be careful not to get your fingers caught during unfolding.**

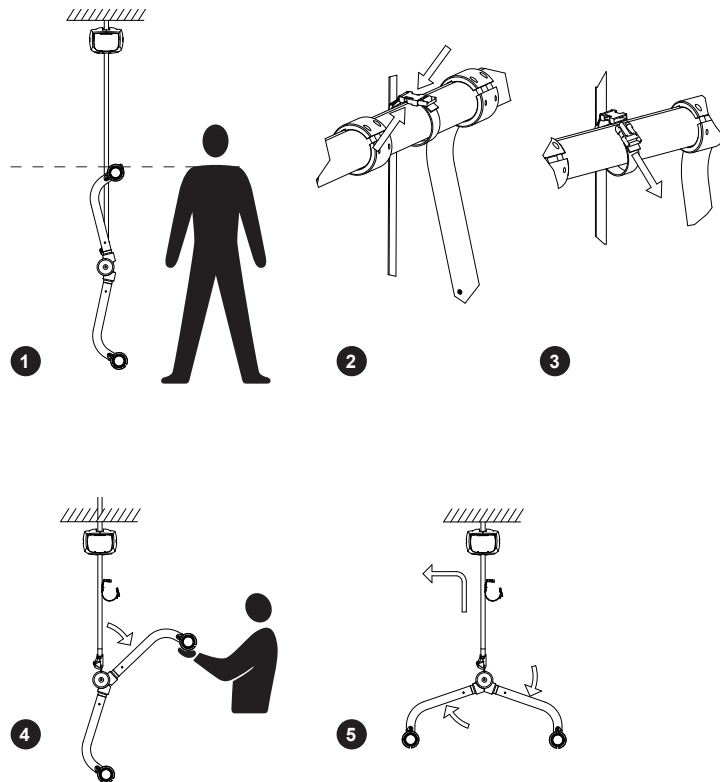

### Set up from a transport trolley (accessory)

Position the hoist centrally over the horizontal lifter in the transport trolley. Attach the snap hook of the hoist to the lifting eye of the horizontal lifter manually; the lifter will be raised by the hoist and will unfold by the lifting movement. **Be careful not to get your fingers caught during unfolding.** When the horizontal lifter unfolds fully, it is safe to use.

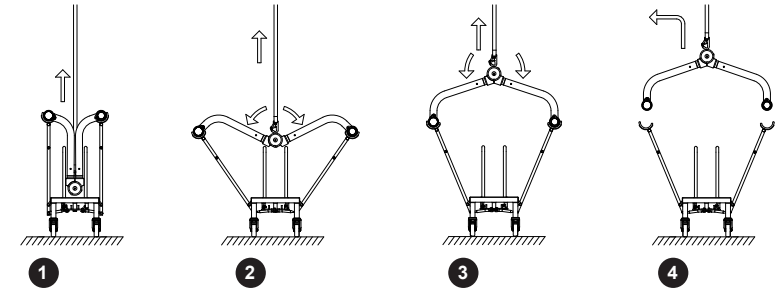

## 1.06

### Sling

The horizontal lifter is used with a sling with 12 straps which are fastened to the strap locks. The individual fastening points must be used two by two and symmetrically to each other.

#### Slings made by other manufacturers

Guldmann disclaims any responsibility for defects or accidents which occur when slings made by other manufacturers are used.

**In case of doubt concerning the selection or use of a lifting sling, please contact your supplier.**

Guldmann disclaims any responsibility for defects or accidents which occur as a result of **incorrect** use of the sling or because of a lack of attention on the part of the helper or the user/patient.

#### When working with a horizontal lifter

Attention should be paid to the functional level of the user/patient and the work technique of the assistant. The user/patient should be lifted only to the extent that she/he is clear of the surface and then moved at this height.

#### Sling application

Place the sling on the horizontal surface alongside the patient with the outside facing down so the labelling faces away from the user/patient. Turn the user/patient in a recovery position, push the sling ahead towards the back of the user/patient and then turn the user/patient back to the middle of the sling. Turn the user/patient afterwards by 1/4 so you can pull the sling out on the opposite side. The user/patient is now placed in the middle of the sling. Fasten the straps to the strap locks by opening the locks, passing the straps through and release the strap lock. The strap lock will automatically close, ensure that the strap is correctly locked. The straps are always fastened from within and towards the assistant.

2.00 Description of features

2.01 Labels

ID number label



Injury warning (yellow)

Foldable horizontal lifter with centre of mass adjustment

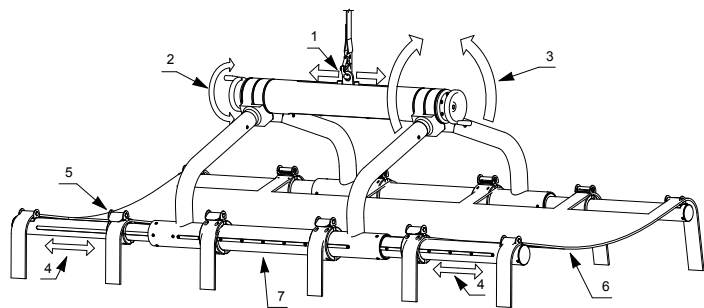

- |   |   |
|---|---|
| 1. Lifting eye for Snap hook            | (Attachment to hoist)                             |
| 2. Handle for centre of mass adjustment | (Horizontal position)                             |
| 3. Folding                              | (Saves room when not in use)                      |
| 4. Telescopic tubes                     | (Save room, length adjustment sling/user/patient) |
| 5. Strap lock                           | (Length adjustment sling/strap)                   |
| 6. Sling/strap set                      |   |
| 7. Telescopic arms                      |   |

Snap hook, strap, extension strap

The lifting eye of the horizontal lifter must always be attached securely to the ceiling hoist during preparation/use, either directly or by means of an extension strap with an approved recommended load (it. 2.02). The snap hook of the ceiling hoist must always be attached in such a way that the lock plate is on.

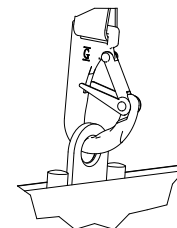

Sling, strap lock

The sling has 12 straps which must be fastened securely to the strap locks.

**Make sure that you turn the sling in such a way that the labelling of the sling faces away from the user/patient.**

The straps are infinitely adjustable; however, the distance from the seam at the end of the strap to the lock should always be at least 30 mm (1¼"). Fasten the straps to the strap locks by opening the locks, passing the straps through and release the strap lock. The strap lock will automatically close, ensure that the strap is correctly locked. See illustrations. The straps are always fastened from within and outward towards the assistant.

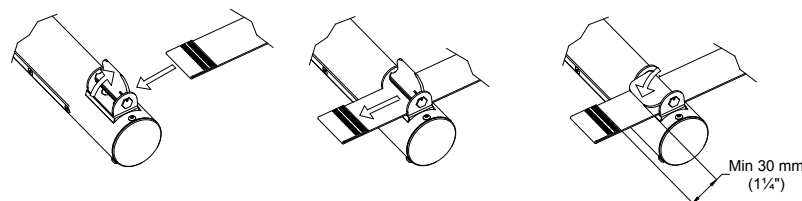

Centre of mass adjustment

The horizontal lifter is equipped with a centre of mass adjustment, refer to item on Page 8, it. 2 on the main drawing. You should strive to place the user/patient in the horizontal lifter in such a way that the lifter is level when the centre of mass adjustment is in a neutral position so as to achieve an even load on both lifter and sling.

You can adjust the centre of mass of the horizontal sling by turning one of the hand wheels placed in each end of the center part. By turning the wheel clockwise, you will raise the horizontal lifter in the end where you turn. By turning the wheel counter-clockwise, you will lower the horizontal lifter in the end where you turn.

Lifting up and down

When all straps are fastened to the strap locks, you can start the lift. You must make sure that the centre of mass adjustment is set correctly before continuing with the lift. If the deviation of the angle is significant (+/-15 degrees) or greater than intended, you need to adjust the centre of mass.

If deviations are too large, the horizontal lifter must be lowered and the user/patient must shift position on the sling.

## Movement

For all movements up/down/horizontally, you must make sure that the horizontal lifter/ sling/user/patient does not come into contact with their surroundings in a way that could give rise to dangerous situations, for example, that the horizontal lifter is brought out of balance or impacts, gets caught in or overturns other objects.

## 2.02

### Accessories

#### Extension strap

When the straps of the hoist are not long enough for the desired movement or lift, you can use a Guldmann extension strap. This can happen, for example, when the hoist system is placed high and you need to be able to lift the user/patient from the floor.

Approved Guldmann extension straps:

126845-100	L = 100 mm (4")
126845-150	L = 150 mm (6")
126845-300	L = 300 mm (11¾") <i>cannot be used together with a strap retainer</i>
126845-400	L = 400 mm (15¾") <i>cannot be used together with a strap retainer</i>
126845-500	L = 500 mm (19¾")
126845-600	L = 600 mm (23½")
126845-700	L = 700 mm (27½")
126845-800	L = 800 mm (31½")
126845-900	L = 900 mm (35½")
126845-1000	L = 1000 mm (39¼")

#### Lifting strap set

Lifting strap set for a horizontal sling Guldmann No. 284430 consisting of:

- 1 head support
- 3 lifting harnesses
- 1 strap for prone lifting

The sling set is primarily intended for use at intensive care units and for persons who cannot tolerate being turned over.

It applies to this sling set, too, that the weight must be distributed among all 12 straps to allow lifting of the max. load. The individual fastening points must be used two by two and symmetrically to each other.

#### Transport trolley

The transport trolley is adapted to transport the horizontal lifter to alternative places of use or storage/cleaning.

#### Strap retainer

The strap retainer is a locking device whose purpose is to minimise the space taken up by the horizontal lifter when it is not in use but is still hanging in the hoist.

You can park the horizontal lifter in a vertical position by locking one of the telescopic sides to the strap retainer on the hoist strap.

## 3.00

### Transport

Guldmann recommends that the horizontal lifter is transported or stored in its original packaging.  
Alternatively, the horizontal lifter can be transported or stored in a transport trolley, which is an accessory to the horizontal lifter.

## 4.00

### Maintenance and storage

#### 4.01

#### Cleaning and maintenance

Clean the horizontal lifter with a damp cloth and ordinary detergent.  
Do not use strong chemicals or an autoclave.

The horizontal lifter does not need any additional maintenance apart from ordinary cleaning.

#### 4.02

#### Storage

Keep the horizontal lifter in a dry room for long-term storage. The best option is a transport trolley or one of the other storage forms described below.

Short-term storage in between uses of the horizontal lifter is described below.

#### Wall bracket (storage)

For storage of the horizontal lifter after use, you can use a wall bracket mounted to a solid vertical wall. The horizontal lifter is then suspended down the wall. The wall bracket must be placed as close to the floor as possible in order to ensure a good working height – the horizontal lift must be able to unfold completely and hang free.

#### Storage on wall bracket

Retract the telescopic tubes fully to minimise size. Then place the two central strap locks in the middle of the horizontal lifter.

Place one of the telescopic arms of the horizontal lifter into the wall bracket by guiding the "hanging" horizontal lifter into the wall bracket manually. Then lower the horizontal lifter until it hangs freely down the wall and the snap hook can be released from the lifter.

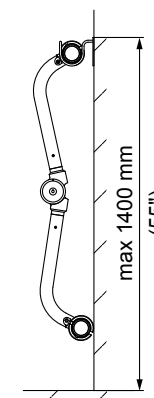

### Strap retainer

If you want the horizontal lifter to be quickly available for use and yet to minimise space, it can be placed in a strap retainer where it remains hanging in the hoist and yet is fixed in a vertical position which requires less space.



### Storage in a strap retainer

The strap retainer is used to minimise the space taken up by the horizontal lifter when it is hanging from the hoist without being used. The strap retainer is attached to the sling straps or to an extension strap.

Open the buckle of the strap retainer and pass the strap through. Close the buckle and pull the strap until it is tight. The buckle is placed with a distance of approximately 540 mm (21¼") between the bottom of the snap hook and the bottom of the clasp.

Afterwards, you can park the horizontal lifter by swinging one of the telescopic arms up and locking the strap around it using the locking clip.

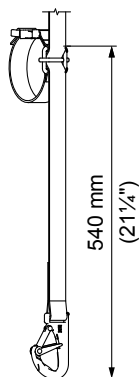

### Transport trolley

If you want to use the hoist at several locations or store it centrally, the horizontal lifter can be placed and transported folded in a transport trolley.

### Storage in transport trolley

Fully retract the telescopic arms to minimise size and place the two central strap locks in the middle of the horizontal lifter.

Place the trolley centrally under the horizontal lift with the arms spread out so the horizontal lifter can be placed into the slot manually while being lowered. The horizontal lifter is then folded in the trolley by means of the lowering movement.

**Do not touch the central part and the hinges of the horizontal lifter during folding, as your fingers can be caught in the moving parts.**

The horizontal lifter is safe to handle when it is fully folded.

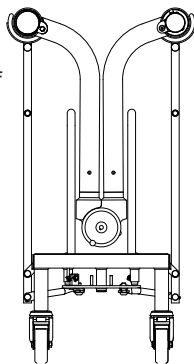

© Guldmann GB\_UK-1229/10/08 • # 944131

© Guldmann GB\_UK-1229/10/08 • # 944131

## 4.03

### Owner's daily maintenance obligations

Check the sling and the sling straps for wear and tear and damages before using them. Do not use the sling if it is damaged or defective.

Do not use the horizontal lifter if the strap locks or other mechanical parts are damaged, loose, defective or missing. Instead, contact your supplier for a service visit.

Make sure that the screws on the horizontal lifter are tightened and that there is no abnormal backlash. Call for a service technician if there is any backlash.

Pay special attention to:

- Screws at the end cover of the central part.
- Screws in the strap locks + the strap lock bracket.

### Replacement of components

Components may be replaced by a qualified service technician or the Guldmann Service Team.

## 4.04

### Disposal of the horizontal lift

Comply with the local and national regulations on environmentally correct recycling. All parts can be separated for recycling.

## 5.00

### Service and service life

## 5.01

### Service life

The horizontal lifter has an expected service life of 10 years, subject to continuous maintenance.

6.00 Technical specifications

Lifting capacity max .....250 kg (550 lbs)  
Weight .....26 kg (57 lbs)

Dimensions

Horizontal lifter, unfolded (W x H x L) ..... 1800 x 970 x 490 mm  
(70¾" x 38¼" x 19¼")

Horizontal lifter, parked (W x H x L)..... 1100 x 230 x 1215 mm  
(43¼" x 9" x 47¾")

Materials

Horizontal lifter.....Aluminium, anodised

7.00 CE declaration of conformity



Guldmann™

EC-DECLARATION OF CONFORMITY

Manufacturer V. Guldmann A/S  
Graham Bells Vej 21-23A  
DK-8200 Aarhus N  
EAN country code: 57  
EAN distribution No.: 07287  
Phone +45 8741 3100  
Fax +45 8741 3131

Representative Company  
Address  
Country  
Phone

Hereby declare that Product **Horizontal lifter, foldable**  
Type No. **XXXXX-YYYY-ZZZZ** <sup>x)</sup>

x) XXXXXX: Reference No. of the product, YYYY: Serial No. of the product in the production year,  
ZZZZ: Production year

was manufactured in conformity with the provisions in:

- EN 10535: Hoists for the transfer of disabled persons  
- requirements and test methods
- EN 12182: Technical aids for disabled persons

according to the Council Directive 93/42/EEC of 14 June 1993

Skejby 01.07.07

Place and day of issue

Product responsible

Technical Manager



## U.S.A. and countries outside the EU

### A. Users guide

Before using the product, read the entire operation manual including all warranties.

### B. WARRANTIES

The Guldmann lifting equipment is designed to be used for the lifting, transferring, and transporting of persons with a physical handicap who are not able to physically self transfer or who are temporarily incapacitated by illness, anesthesia or other causes.

This lifting equipment is designed to relieve the users, their caregivers, and nursing personnel in the task of lifting elderly or handicapped people, thereby minimizing the risk of back injury during such lifting and transfer operations. If the product is used irresponsibly or for any use other than that described above or in the enclosed written instructions, the manufacturer's warranty will be nullified and rendered void.

There are no warranties which extend beyond the description in the enclosed written instructions.

Guldmann warrants that its lifting equipment is free from defects in materials and workmanship under normal use. Guldmann warrants that the lifting equipment itself will perform substantially in accordance with the specifications set forth in the documentation provided with the equipment.

The above express warranties are made for a period of 365 days from the date the lifting equipment is delivered to you as the first user.

Your distributor will replace any lifting equipment which proves defective in materials or workmanship, without additional charge, on an exchange basis.

Your distributor will either replace or repair without additional charge any Guldmann lifting equipment that does not perform in substantial accordance with the specifications of the document.

Guldmann does not warrant that the functions contained in the lifting devices will meet your requirements or that the operation of the services will be uninterrupted or error-free. The warranty does not cover any of the part of the lifting equipment which has been subject to damage or abuse by you. The warranty does not cover any part of the lifting equipment which has been altered or changed in any way by you or others. Guldmann is not responsible for problems caused by changes in the operating characteristics of the operating system which are made after the delivery of the lifting equipment. Any implied warranties including any warranties of merchant ability or fitness for a particular purpose are limited to the term of the express warranties.

Guldmann shall not in any case be liable for special, incidental, consequential, indirect or other similar damages arising from any breach of these warranties even if Guldmann or its agent has been advised of the possibility of such damages.

You must call Guldmann or your distributor for an authorization to return any defective item during the warranty period. If your distributor is unable to correct your problem by telephone, you will be provided with a return authorization number and address for returning the defective item for warranty service or replacement. You must insure any defective item being returned because Guldmann does not assume the risk of loss or damage while in transit. Do not return items or warranty service to Guldmann.

The warranties set forth above are in lieu of all other express and implied warranties, whether oral, written or implied, and the remedies set forth above are your sole and exclusive remedies. Only an authorized officer of Guldmann may make modifications to this warranty, or additional warranties binding on Guldmann. Accordingly, additional statements such as advertising or presentations, whether oral or written, do not constitute warranties by Guldmann and should not be relied upon as such. The warranty gives you specific legal rights, and you may also have the other rights which vary from state/country to state/country.



**taylordolman**

tel: 0845 838 0600

email: [info@taylordolman.com](mailto:info@taylordolman.com)