

## GH2 HD Twin Ceiling Hoists Technical specifications

# Guldmann™

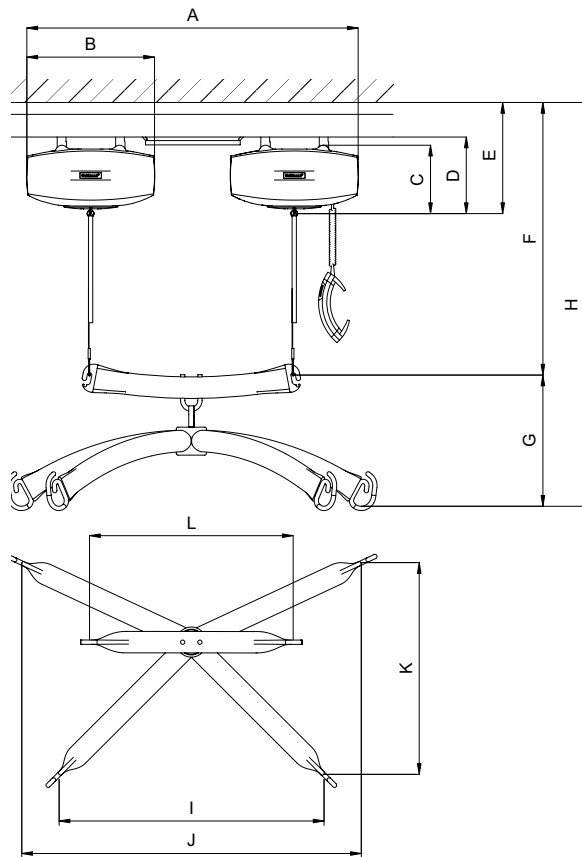

### Measurements

A	: 770 mm
B	: 300 mm
C	: 148 mm
D	: 160 mm
E	: Min. 242 mm
F	: Min. 382 mm
G	: 295 mm
H	: 692 - 2692 mm
I	: 620 mm
J	: 790 mm
K	: 490 mm
L	: 473 mm
Angling of connecting bar	: ± 12°
Depth of lifting unit	: 197 mm

### Safety Measures

Emergency stop	: Yes
Emergency lowering	: Yes, electronic
Lifting strap	: No risk of twisting the strap during lifting

### Electrical parts

On/off	: Automatically
Power consumption	: 240 VA
Periodic load	: 15/85
Batteries	: 4 pcs 12V Sealed and maintenance free
Battery protection	: Switches off automatically when voltage goes below 17 volt Diode flashes to indicate voltage is critical
Electricity supply	: 24V AC/DC
Output transformer	: 40VA
Output recharger	: 32VA
Supply voltage transformer or recharger	: 100-240V
Charging time	: Max. 8 hours

### Classification, tightness

Hoist and hand control	: IP 20
Microswitch for hand control:	IP 67

### Markings

CE-marked according to DS/EN 10535	: Hoists for the transfer of disabled persons
EN 60601-1-2	: Medical electrical equipment
Directive 93/42/EEC	: Medical devices

### Item Number/Model

120001-6023	: GH2 HD Twin AC excl. connecting bar and cross hanger
120001-7023	: GH2 HD Twin DC excl. connecting bar and cross hanger

### Classification

according to ISO 9999	: 12 36 12
-----------------------	------------

### Functions

Lifting capacity	
with cross hanger	: Max. 455 kg
with horizontal lifting support	: Max. 250 kg
Max. number of lifts in series (AC)	: 62 with 250 kg/1000 mm 31 with 455 kg/1000 mm
Max. number of lifts in series (DC)	: 49 with 250 kg/1000 mm 28 with 455 kg/1000 mm
Lifting speed	
with 250 kg load	: 1585 mm/min
with 455 kg load	: 1160 mm/min
Operation	: Hand control with level adjustment

### Weight and Materials

Weight	
Lifting units	: 17,4 kg without hanger
Connecting bar	: 1,3 kg
Cross lifting hanger	: 6,5 kg
Materials	
Lifting units	: Covers - impact-proof recyclable plastic/ V0 fire-retardant
Connecting bar and cross hanger	: Rustproof steel, electropolished

Time to care