



Guldmann Mobile lifter GL5 – 100 mm castors Technical specifications

Functions

Lifting capacity, max	: 155/205 kg
Lifting speed with 85 kg load	: 36 mm/sec
Number of lifts per charging	: 50 lift with 85 kg
Lifting interval	: 1302 mm
Pushbutton	: 3.3 N

Operation

Lift	: Electric
Width adjustment	: Electric

Weight

Totally	: 46 kg
Chassis	: 22 kg
Mast + lifting boom	: 25 kg
Charger + handcontrol	: 1,0 kg

Measurements

A.	: 69 mm
B.	: 143 mm
C.	: 2013 mm
D.	: 1370 mm
E.	: 229 mm
F.	: 518 mm
G.	: 1382 mm
H. min/max	: 664/1967 mm
I. min/max	: 456/1759 mm
J. min/max	: 530/1300 mm
K. min/max	: 695/1410 mm

Turning radius

Turning radius:	: 1295 mm
-----------------	-----------

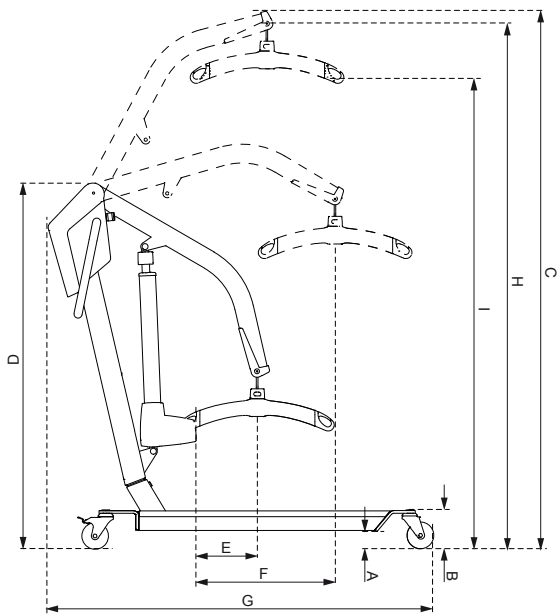

Safety Features

Emergency stop	: Yes
Emergency lowering	: Yes, electronic. Mechanical on request
Protection against trapping	: Yes

Electrical parts

On/off	: Automatically
Power supply for charging	
Input	: 100-240Vac, 47-63Hz, 0.6-0.4A
Output	: 36V, 0.83A
Battery, replaceable NiMH	: 24V /4.5 Ah
Charging time	: Max. 5 hours
Consumption/power of actuator	: 24V, max 8A
Duty Cycle	: Max 10%, max. 2 min on, 18 min off.
Battery protection	: Switches off automatically at low voltage. Diode flashes to indicate critical voltage

Class of tightness

Mobile hoist	: IP 30
Hand control	: IP 44
Power supply:	: IP 20

Accessories/Miscellaneous

Lifting hanger	: To be ordered separately
----------------	----------------------------

Labelling

The product is manufactured in compliance with the Council Directive 93/42/EEC of June 14th 1993, including amendments, as medical device class 1.

Item Number/Model

555000	: 205 kg, 100 mm castors
555001	: 155 kg, 100 mm castors
555002	: 205 kg, 100 mm castors, manual lowering
555003	: 155 kg, 100 mm castors, manual lowering

Classified

acc. to ISO 9999	: 12 36 03
------------------	------------

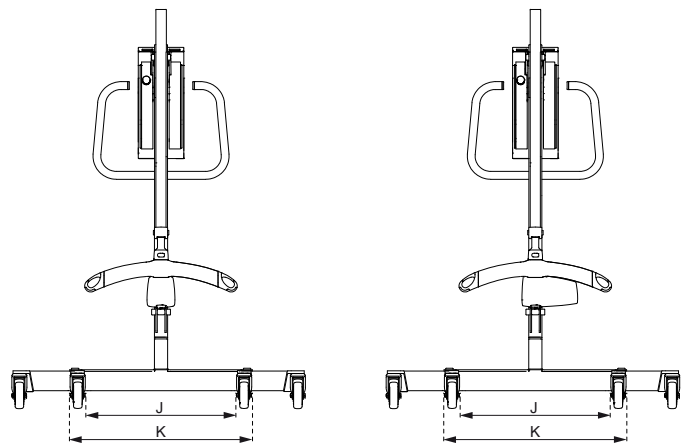

Time to care